

THIS DRAWING IS UNPUBLISHED, RELEASED FOR PUBLICATION, 19

© COPYRIGHT 19 BY AMP INCORPORATED, HARRISBURG, PA. ALL INTERNATIONAL RIGHTS RESERVED. AMP PRODUCTS MAY BE COVERED BY U.S. AND FOREIGN PATENTS AND/OR PATENTS PENDING.

REVISIONS					
P/F	ZONE	LTR	DESCRIPTION	DATE	APPROVED
<input checked="" type="checkbox"/>		A	RELEASED	P.A.R	2-20-85 RLT/67
<input checked="" type="checkbox"/>		B	REVISED	AF-1152	9/12/85 JSE/47
<input checked="" type="checkbox"/>		C	REVISED PER 063A-0109-02	05 MAR 02	MSF/

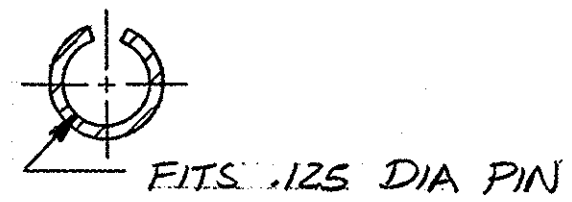
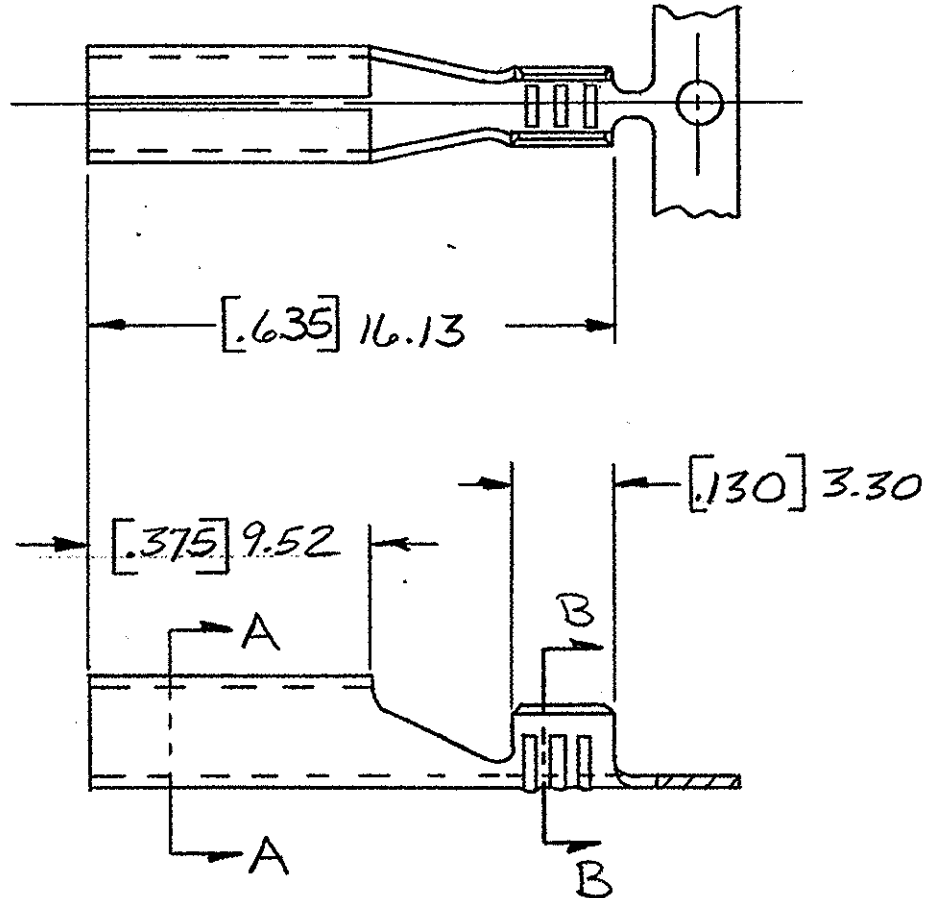

SECT. A-A

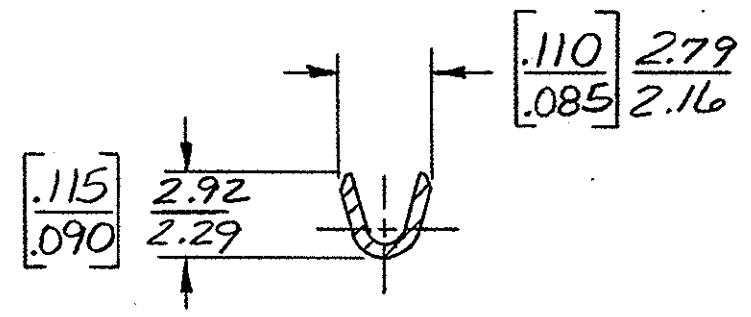

SECT. B-B

- 1 - DIMENSIONS IN BRACKETS ARE IN INCHES
- 2 - CONTINUOUS STRIP ON REELS
- 3 - PRELIMINARY - NOT FOR PRODUCTION.

METRIC

TIN	[22-18] 0.3-0.8 mm ²	3 63381-2
NONE	[22-18] 0.3-0.8 mm ²	63381-1
FINISH	WIRE SIZE	PART NO
UNLESS OTHERWISE SPECIFIED DIMENSIONS ARE IN INCHES. TOLERANCES ON: DECIMALS [±.010] 0.25 ANGLES ±	CONTRACT NO	AMP INCORPORATED Harrisburg, Pa.
MATERIAL [0.014] 0.36 BRASS	DR. <i>J.R. Rutt</i> 12/18/84 CHK. <i>G. Yetter</i> 12/18/84	
FINISH SEE TABLE	APPD. <i>J. Bonk</i> 12/19/84 APPD. <i>J. H. Gentry</i> 12/20/84	NAME .125 DIA. PIN RECEPTACLE
	DSGN APPD	SIZE B FSCM NO 00779 DRAWING NO 63381
	OTHER APPD	SCALE SHEET